

AFFASER HTM 16

smart tools
for heavy tasks



Portable, handy beveling machine is designed for milling edges of plates and pipes made of steel, aluminum alloys, brass, or plastic.

Depending on the chosen milling head the machine enables beveling materials with minimum thickness of 1.5 mm (0.06") at the angles of 22.5°, 30°, 37.5°, 45°, 55° or 60° and with maximum bevel width of 16 mm (0.63").

Each milling head uses 5 indexable cutting inserts.

One milling head for beveling radius enables beveling edges with radius of 2, 3, 4 or 5 mm with use of 4-sided indexable R2, R3, R4 or R5 cutting inserts.

Countersinking of holes with minimum 40 mm (1.57") diameter is also possible.

BM-16 is equipped with continuous bevel width adjustment, overload protection and electronic speed control for use on a variety of materials.

It is highly efficient machine for edge weld preparation and rounding off steel construction before painting or coating.

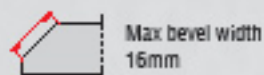

Max bevel width
16mm

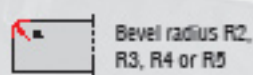

Bevel radius R2,
R3, R4 or R5

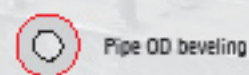

Pipe OD beveling

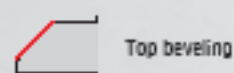

Top beveling



Arched edge
beveling

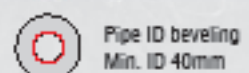

Pipe ID beveling
Min. ID 40mm

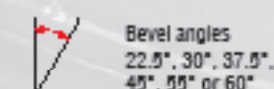

Bevel angles
22.5°, 30°, 37.5°,
45°, 55° or 60°

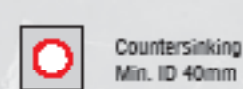

Countersinking
Min. ID 40mm

BM-16 TECHNICAL SPECIFICATION	
Power supply	220-240 V / 50-60 Hz or 110-120V / 60Hz
Motor	2200W
Spindle speed (without load)	1880-6250 rpm
Maximum bevel width	b=16 mm (0.63", Figure 1)
Bevel angle (depending on milling head)	$\beta = 22.5^\circ, 30^\circ, 37.5^\circ, 45^\circ, 55^\circ, 60^\circ$ (Fig.1)
Minimal diameter of countersinking	ca 40 mm (1.57")
Rounding edges	R2, R3, R4, R5 (Fig. 2)
Dimensions (L x W x H)	585 mm (23.0") x 156 mm (6.1") x 238 mm (9.4")
Weight (without milling head)	10 kg (22 lbs)
Product code (220-240 VAC)	UKS-0509-10-20-00-0
Product code (110-120 VAC)	UKS-0509-10-10-00-0



Steel plate beveling



Arched edge beveling with radius

Basic set:

- BM-16 beveling machine without accessories (see list below)
- Metal box
- 52mm flat wrench
- Allen wrench hex s=5
- Allen wrench hex s=14
- Operator's Manual (English)

Accessories:

- GLW-000011 - Milling head for rounding
- PLY-000360 - Cutting insert R2 (4pcs required)
- PLY-000159 - Cutting insert R3 (4pcs required)
- PLY-000160 - Cutting insert R4 (4pcs required)
- PLY-000161 - Cutting insert R5 (4pcs required)

- GLW-000010 - Milling head 22,5°
- GLW-000005 - Milling head 30°
- GLW-000009 - Milling head 37,5°
- GLW-000006 - Milling head 45°
- GLW-000008 - Milling head 55°
- GLW-000007 - Milling head 60°
- PLY-000294 - Cutting insert for steel (5pcs required)
- PLY-000195 - Cutting insert for aluminium (5pcs required)

Spare and consumable parts:

- SFB-000289 - Insert Screw
- SFB-000290 - Insert Screw (Radius)
- RLK-0509-03-00-00-0 - Guiding roller
- SMR-000005 - Screw grease (5 g)
- Carbon brush for 115 V
- Carbon brush for 230 V

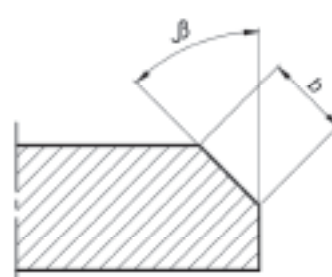

Fig. 1

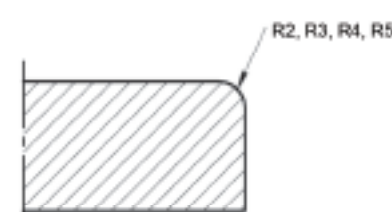
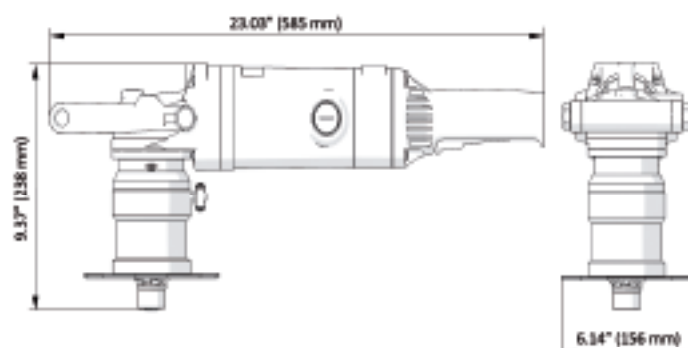

Fig. 2



Aluminium beveling



Curved edge beveling



Pipe beveling



Countersinking



HAJO TOOL
PROFESSIONELT SPECIALVERKTYG

Vejlegrænvej 46 B
DK-2946 Vesterhavns Skovvej
TEL: 4444 2400 • FAX: 4444 0833
www.hajo.dk • hajo@hajo.dk